

The Mechanics of Tractor - Implement Performance

Theory and Worked Examples

A TEXTBOOK FOR STUDENTS AND ENGINEERS

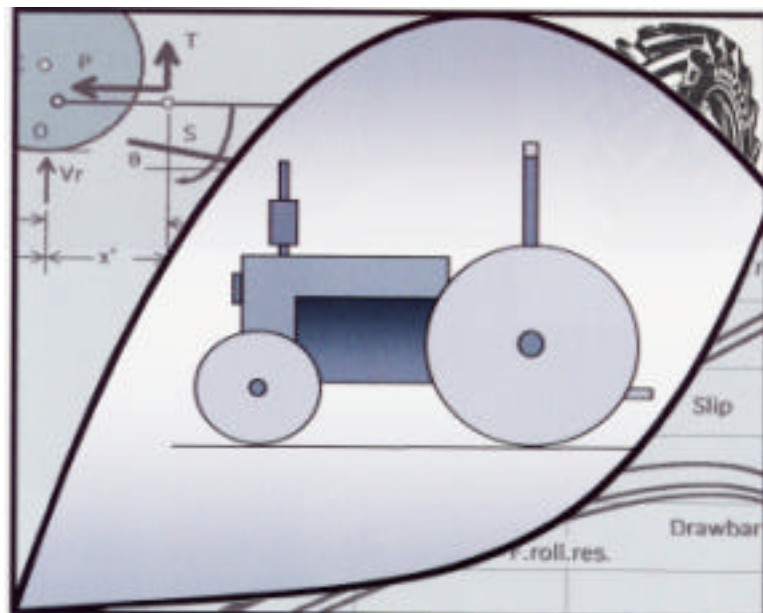

R. H. Macmillan

*Senior Academic Associate, Agricultural Engineering
International Development Technologies Centre
University of Melbourne*

Printed from: <http://www.eprints.unimelb.edu.au>

Dedication

For my parents . . .

Philosophy

‘To the writer however, the most important reason for the study of soil - vehicle mechanics is an educational one. The training of agricultural engineers at University level is a relatively new enterprise which aims at producing creative engineers in a shorter overall period than the old method of practical experience alone. In order to achieve this the University must concentrate on the teaching of principles and the scientific method applied to each particular field. The young engineer must then add to this some years of experience of the application of these principles and must support them with adequate background knowledge.

If the scientific approach is the aim of academic agricultural engineering, then it is plain that the principles of soil vehicle mechanics (and soil implement mechanics) must form an important part of the teaching. Unfortunately in this, as in other branches of agricultural engineering, the principles are obscure and can only be taught after considerable research on the part of the teacher. The research effort . . . is not aimed at the direct improvement of the farm tractor but rather at the elucidation of principles which can be taught to students who will use them in the development of better machines.’

A.R. Reece

Prayer

I offer you tonight, Lord, the work of all the tractors . . . in the world.

Prayers of Life: Michel Quoist

PREFACE

This book arose out of the experience that the author has had in teaching courses on tractor performance for a number of years particularly at the University of Melbourne. It has been written primarily for student use in agricultural and mechanical engineering courses at University and College level and as such, it assumes:

- (a) a knowledge of basic mechanics, stress analysis, soil mechanics and power transmission elements appropriate to second year professional engineering courses;
- (b) a general knowledge of the layout and operation of the tractor.

The need for such a book arose out of the fact that, while there are other books written on the general topic of the agricultural tractor, none treat the subject of tractor performance in an adequate way that builds on the engineering science which is covered in first and second year engineering courses. Existing books tend to be too broad, being written to cover the whole subject from the design of engine components to the economics of use. Others, that are written essentially for users, merely describe the tractor and its operation. Nor is there a book written that provides an suitable background for general engineers wishing to 'break into' the technical or research literature.

In writing this book an attempt has been made to keep the discussion as general as possible. It is concerned with principles and does not become involved in consideration of the details of individual types of tractor even to the point of not distinguishing between two wheel (walking) and four wheel tractors (except in relation to chassis mechanics).

Further no attempt has been made to describe the construction of the tractor or its various components and operational systems. For those who wish to learn these details, reference should be made to the engineering textbooks specifically written on these topics and other books on the agricultural tractor that includes them.

The understanding of the concepts on which a book such as this is based owes much to many others who have published material on this subject; the author gratefully acknowledges the material that others have contributed in this way. However, two people and their associated groups must be mentioned in particular.

The first is the late G.H. Vasey and his colleagues at the University of Melbourne. Their development of the graphical representation of tractor performance (on which Chapter 3 is based) still provides the clearest understanding of the subject for students and others who would learn from it.

The second is A.R. Reece and his colleagues at the University of Newcastle-on-Tyne, England. Chapter 4 which is largely based on their work (and earlier work by Bekker) provides an understanding of the traction process in terms of engineering fundamentals that are suitable for use at the student level. Indeed the educational philosophy as presented by Reece (1964) on the dedication page seems entirely appropriate for this work.

The demise of agricultural engineering courses in developed countries and the need for cheap, basic educational materials in developing countries prompted the compilation of this work. Its publication on the University of Melbourne web site makes it available to a wide range of readers at little cost; it is hoped that, like the author, they will appreciate this facility!

The author also wishes to acknowledge the support of his colleagues, in particular the secretarial assistance of Ms. J. Wise, the comment on the text by Dr. Nguyen Phu Thien and the assistance in arranging for its publication on the University of Melbourne web site by Dr. Graham Moore. The support of the Universities of Melbourne, Australia and Hohenheim, Germany in providing the opportunity for study leave, during which much of the final compilation of the work took place, is also acknowledged.

The encouragement and help of his wife Joan in the checking the manuscript and in many other ways is cause for gratitude.

The author would value notification of any errors in this work.

CONTENTS

CHAPTER 1

THE AGRICULTURAL TRACTOR	1.1
1.1 INTRODUCTION	1.1
1.1.1 General	1.1
1.1.2 Justification	1.1
1.1.3 Development	1.1
1.1.4 Classification of types	1.2
1.2 FUNCTIONAL REQUIREMENTS AND LIMITATIONS	1.2
1.2.1 Functional requirements	1.2
1.2.2 Performance limitations	1.2
1.3 SYSTEMS AND POWER OUTLETS	1.4
1.3.1 Engine	1.4
1.3.2 Transmission systems and outlets	1.6
1.3.3 Wheels	1.10
1.4 STUDYING TRACTOR PERFORMANCE	1.10
1.4.1 Need for the study	1.10
1.4.2 Approaches to the study	1.11
1.5 PREVIEW	1.12
1.6 REFERENCES	1.12

CHAPTER 2

TRACTOR MECHANICS	2.1
2.1 INTRODUCTION	2.1
2.2 IDEAL ANALYSIS (WITHOUT LOSSES)	2.1
2.2.1 Speed analysis	2.1
2.2.2 Torque / force analysis	2.2
2.2.3 Power analysis	2.2
2.2.4 Ideal performance graphs	2.5
2.2.5 Performance envelopes	2.5
2.2.6 Conclusion	2.5
2.3 ANALYSIS WITH LOSSES	2.7
2.3.1 Speed analysis	2.7
2.3.2 Force analysis	2.7
2.3.3 Power analysis	2.7
2.4 OTHER MEASURES OF PERFORMANCE	2.8
2.4.1 Efficiency	2.8
2.4.2 Tractive coefficient	2.10
2.5 SUMMARY	2.10
2.6 REFERENCES	2.10

CHAPTER 3

TRACTOR PERFORMANCE ON A FIRM SURFACE	3.1
3.1 INTRODUCTION	3.1
3.2 ENGINE PERFORMANCE	3.3
3.2.1 General	3.3
3.2.2 Output	3.3
3.2.3 Input	3.7
3.3 TRACTOR DRAWBAR PERFORMANCE	3.11
3.3.1 Output	3.11
3.3.2 Input	3.13
3.3.3 Other measures of performance	3.14
3.4 REFERENCES	3.16

CHAPTER 4

TRACTOR PERFORMANCE ON SOFT SOIL – THEORETICAL	4.1
4.1 INTRODUCTION	4.1
4.1.1 General	4.1
4.1.2 Definitions	4.1
4.1.3 Operational states of a wheel	4.3
4.1.5 Wheel slip definition	4.4
4.1.6 Wheel slip measurement	4.4
4.2 TRACTIVE PERFORMANCE	4.6
4.2.1 Practical / experimental measurement	4.6
4.2.2 Theoretical prediction	4.6
4.2.3 Empirical prediction	4.6
4.3 ROLLING RESISTANCE	4.8
4.3.1 Wheel conditions	4.8
4.3.2 Theoretical prediction	4.8
4.3.3 Experimental measurement	4.14
4.3.4 Empirical prediction	4.14
4.4 TRACTIVE FORCE	4.14
4.4.1 Introduction	4.14
4.4.2 Shear stress - deformation characteristic for soil	4.14
4.4.3 Analysis of locked track	4.16
4.4.4 Analysis of track with slip	4.20
4.5 DRAWBAR PULL	4.22
4.6 DRAWBAR POWER	4.24
4.6.1 Wheel slip - drawbar power characteristic	4.24
4.6.2 Theoretical prediction of optimum wheel slip	4.26
4.7 GENERAL PROBLEMS	4.30
4.8 REFERENCES	4.31

CHAPTER 5

TRACTOR PERFORMANCE ON SOFT SOIL – EMPIRICAL	5.1
5.1 INTRODUCTION	5.1
5.1.1 General	5.1
5.1.2 Empirical method	5.1
5.2 ENGINE PERFORMANCE MODELING	5.1
5.3 TRACTIVE PERFORMANCE MODELING	5.2
5.3.1 Parameters	5.2
5.3.2 Prediction of performance measures	5.6
5.4 TRACTOR DRAWBAR PERFORMANCE	5.12
5.4.1 Performance in various gears	5.12
5.4.2 Distribution of power components	5.14
5.4.3 Effect of surface and weight	5.16
5.5 CONCLUSION	5.17
5.6 REFERENCES	5.17

CHAPTER 6

HITCHING AND MECHANICS OF THE TRACTOR CHASSIS	6.1
6.1 INTRODUCTION	6.1
6.2 IMPLEMENT HITCHING	6.1
6.2.1 Introduction	6.1
6.2.2 Hitching systems	6.3
6.3 TRACTOR CHASSIS MECHANICS	6.3
6.3.1 Centre of gravity	6.3
6.3.2 Issues	6.8
6.3.3 Analysis and assumptions	6.9
6.4 WEIGHT TRANSFER	6.11
6.4.1 Four wheel tractor	6.11
6.4.2 Weight transfer with rolling resistance	6.15
6.4.3 Weight transfer with hitching systems	6.21
6.4.4 Other examples	6.28
6.5 IMPENDING INSTABILITY	6.36
6.6 REFERENCES	6.40

CHAPTER 7

TRACTOR - IMPLEMENT MATCHING AND OPERATION	7.1
7.1 INTRODUCTION	7.1
7.2 IMPLEMENT PERFORMANCE	7.1
7.2.1 Implement draught	7.1
7.2.2 Implement draught - speed characteristic	7.3
7.2.3 Implement power	7.3
7.2.4 PTO driven and towed implements	7.3
7.3 TRACTOR - IMPLEMENT PERFORMANCE	7.5
7.3.1 Operating conditions	7.5
7.3.2 Optimum performance criteria	7.5
7.3.3 Matching wheels and engine	7.9
7.4 MATCHING TRACTOR AND IMPLEMENT	7.10
7.4.1 Variables available	7.10
7.4.2 Optimising performance	7.10
7.4.3 Setting up tractor and implement	7.12
7.5 OPERATING THE TRACTOR	7.14
7.6 REFERENCES	7.15

CHAPTER 8

GENERAL PROBLEMS	8.1
-------------------------	------------

APPENDICIES

LIST OF SYMBOLS	I
DIMENSIONAL DATA FOR FARMLAND TRACTOR	II

CHAPTER 1

THE AGRICULTURAL TRACTOR

1.1 INTRODUCTION

1.1.1 General

The agricultural tractor is one of the class of mobile machines that involves the 'traction' process. The word 'traction' and name 'tractor' come from the word to 'draw' or 'pull' so a tractor is basically a machine for pulling; other mobile machines such as locomotives are in the same class. Vehicles like road trucks and even motor cars, which are essentially vehicles for carrying loads, also involve the traction process.

The tractor is also in the class of machines that involves operation under what are known as 'off-road' conditions. Others in this class include machines used in earth moving, mining and military work, also four-wheel drive motor vehicles for cross - country operation.

1.1.2 Justification

The question is often asked as to what is so special about the tractor and its operation that would justify its study as a machine in its own right. This may be answered by considering the conditions under which the tractor is expected operate.

- (i) The agricultural soils, on which the tractor operates, are 'weak', ie, they slip (shear) when loaded horizontally and compact (compress) when loaded vertically. This condition, which the tractor and its attached implement are frequently being used to produce, is usually ideal from an agricultural point of view but is not conducive to efficient operation from a tractive point of view.
- (ii) The loading conditions on the tractor are variable from job to job and, for efficient operation, ideally require the tractor to be set up to suit each condition.
- (iii) The operating conditions for the tractor are highly variable both in time and place, which requires continual monitoring and adjustment of both tractor and implement in operation.
- (iv) The ground surfaces are rough and sloping, hence both tractor and implement control is difficult; instability is an ever-present danger. This is important because the tractor must be able to be operated by non-specialists.
- (v) A clearance above growing crops and the ability for the operator to see the ground.

The tractor must function effectively and efficiently while satisfying these often conflicting requirements. The study of the tractive processes on soft soils and the dynamics of implement control, are unique to the agricultural tractor and justify specialized analysis, research and design. The present work builds on elementary aspects of the published literature on these studies and seeks to provide a basis for 'breaking into' the technical and research literature.

1.1.3 Development

The tractor evolved in the second half of the 19th century and first half of the 20th into its present, conventional, two wheel drive form and four wheel drive variation. This form owes much to history but also the fact that it is an inherently logical arrangement.

- (i) Designers followed early tractor designs that were simply replacements for horses or other draught animals.
- (ii) The layout takes advantage of the transfer of weight to the main driving wheels at the rear, as the drawbar pull on the tractor increases.
- (iii) The layout is inherently stable in the horizontal plane because the implement commonly being pulled behind the tractor tends to follow the latter and to pull it into straight line operation.
- (iv) Rear mounted implements offer a minimum of offset loading and moment in the horizontal plane; this contrasts with, for example side mounted implements.

As a result there has been little or no major change in the basic lay-out of tractor / implement systems over their period of development although there have been major improvements in engines, transmissions, tyres, control systems and drivers' accommodation.

1.1.4 Classification of types

Tractors may be classified according to their basic form, which in turn depends on the function that each type is designed to achieve. They may be classified as follows.

- | | | |
|-------|------------------------------------|--|
| (i) | Number of axles | * one - walking
* two - conventional, riding |
| (ii) | Number of driven axles | * one - conventional and walking
* two - four wheel drive |
| (iii) | Ground drive elements ¹ | * wheels and tyres, lugs, strakes
* tracks - crawler, track laying |
| (iv) | Use of wheels | * traction - conventional
* propulsion / cultivation - power tiller |

Illustrations and descriptions of the various forms of tractor and the associated terminology may be found in other textbooks (Liljedahl et al (1989)).

1.2 FUNCTIONAL REQUIREMENTS AND LIMITATIONS

1.2.1 Functional requirements

Although it is able to undertake a multitude of specific tasks, the functions of the tractor can be reduced to the following (Reece 1971):

- (i) the provision of up to full power in the form of a large drawbar pull (compared to the weight of the tractor) at low speeds. The highly variable loading that occurs in agricultural work requires consideration of tractor performance at part load, particularly with respect to fuel consumption.
- (ii) the provision of power for driving and control of a range of implements and machines performing various tasks and attached in a variety of ways.
- (iii) the provision of power as the basis for a transport system in both on- and off-road conditions.

The main emphasis in this book is on how the tractor performs these functions, ie, on its functional performance. There are of course other ways by which tractors might be evaluated such as by their economy, reliability, safety or ease of operation. These are important but are beyond the scope of this book.

1.2.2 Performance limitations

Since its main function is to pull (or push), the question arises as to how well and within what limits the tractor succeeds in performing those functions. How we might measure and represent that performance is also of interest. This output is expressed, as in engineering mechanics, in terms of force (engine torque and drawbar pull), speed (rotational and travel), power (engine and drawbar) and non-dimensional numbers (wheel slip, tractive efficiency). The input is performance is expressed in terms of fuel consumption (actual and per unit power output).

¹ Hereafter the term 'wheels' will be used to cover all elements unless a specific reference is intended.

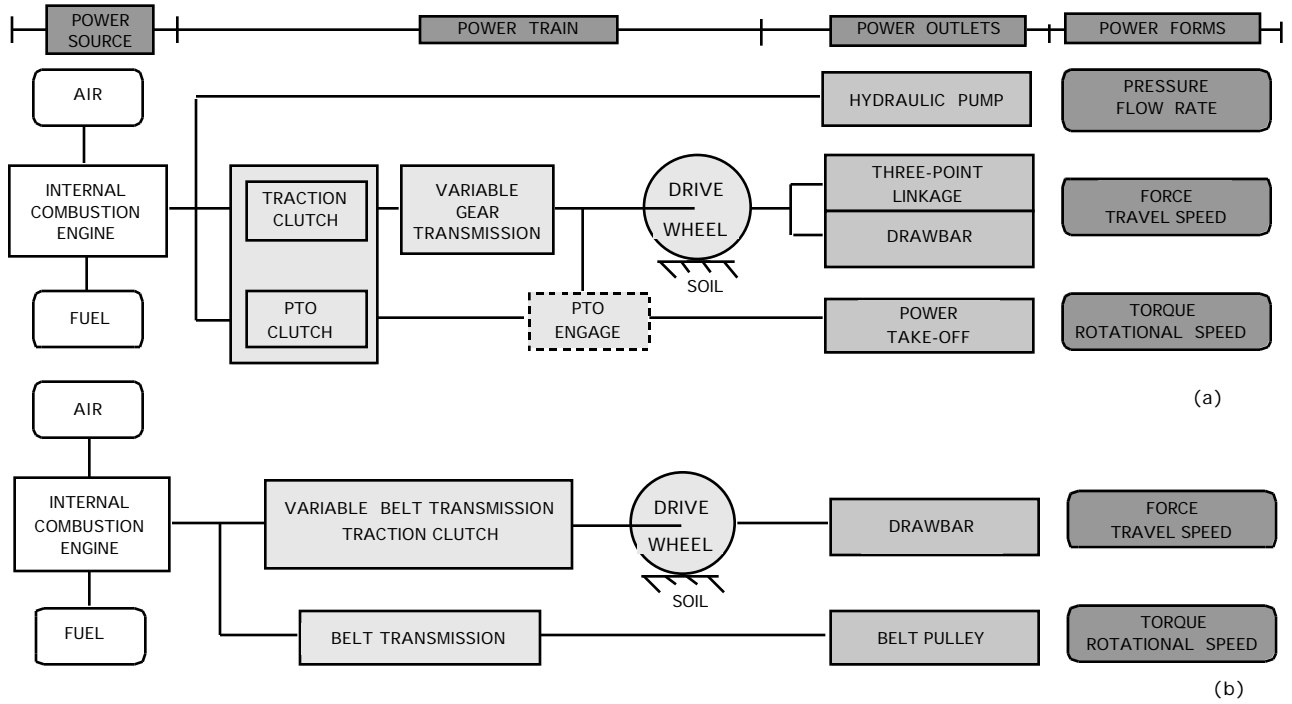

Figure 1.1: Typical power trains (a) for a conventional tractor and (b) for walking tractor / power tiller

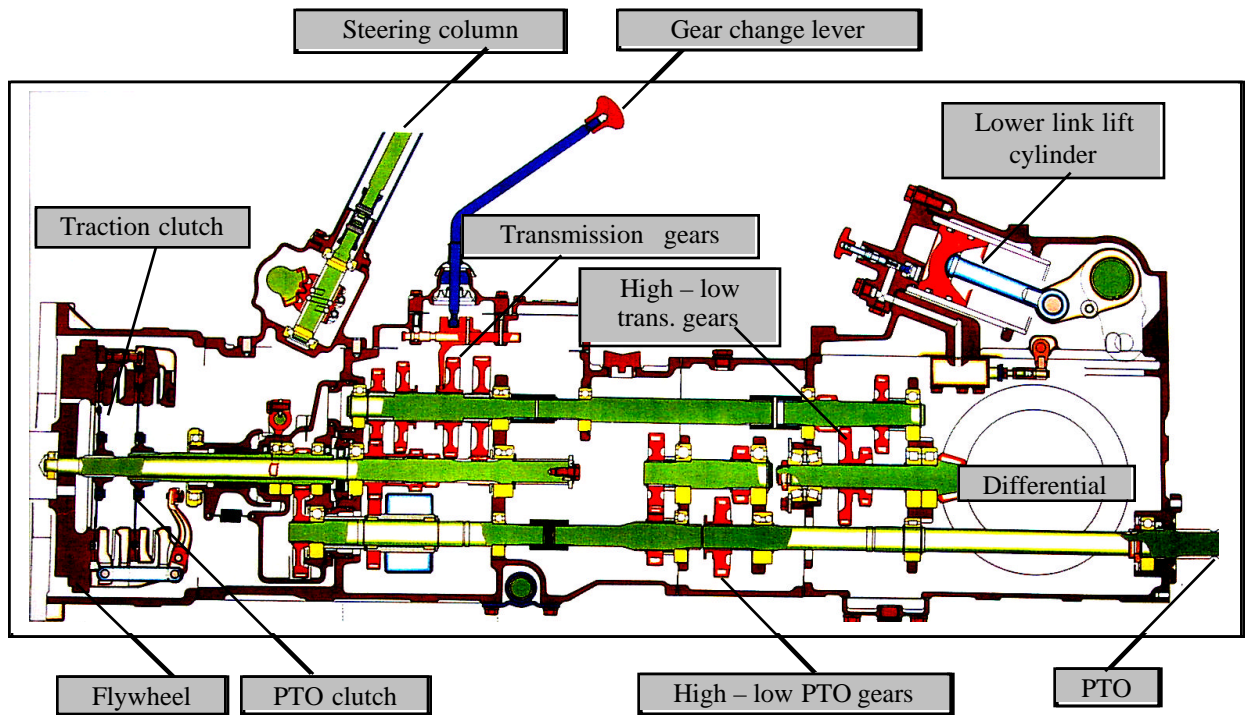

Figure 1.2: Transmission system for a conventional gear drive tractor (Kubota L345)
 Reproduced with permission of Kubota Tractor (Australia)

The overall limitations to performance are also explored in this book as follows:

- (i) At higher travel speeds the limit is engine stall (stopping); optimum engine loading and fuel consumption are achieved by appropriate choice of engine speed and gear ratio.
- (ii) At lower travel speeds in which the limit is wheel slip; the optimum wheel slip is achieved by an appropriate choice of the magnitude of the drawbar load also the weight on and size of the tyres, particularly on the driving wheels.
- (iii) On steep slopes and / or when an incorrect hitch is used; this instability (in the longitudinal plane) is overcome by limiting operation to appropriate slopes and using correct hitching.

Other limitations (not directly associated with performance) such as the actual occurrence of longitudinal and lateral instability, and the loss of steering control due, for example, to vibration, are also beyond the scope of this book.

1.3 SYSTEMS AND POWER OUTLETS

Tractors are built in many forms and sizes according to the particular functions that they are required to perform. However, in reviewing their performance it is sufficient to consider the major systems and power outlets that are common to most tractors. The block diagram of the main components in the power transmission system, including the power outlets and forms, is shown in Figure 1.1 (a) for a conventional tractor with PTO and hydraulic power outlets and in Figure 1.1(b) for a walking tractor / power tiller.

The following systems can be identified.

1.3.1 Engine

The engine, which is the immediate source of energy for the operation of the tractor, varies in type and size according to the type and size of the tractor to which it is fitted. It is a mechanism which, using air, extracts the energy from the fuel and transforms it into a mechanical (rotational) form.

Its output (in terms of torque, speed and power) is determined by the physical size of the engine (which determines the amount of air that can be drawn in), the fuel burnt in that air and its speed of operation. Its performance, which is represented in terms of the fundamental characteristic for the engine, ie, the relationship between the torque and (rotational) speed, largely determines and of course limits the performance of the tractor. These are discussed in Chapter 3.

Many other aspects of engine design and operation affect its performance. These include the engine processes (the cycle of strokes on which it operates), the type of fuel and its method of ignition (spark or compression ignition) and the mechanical details such as the design of the components (pistons, crankshaft, valves) and the services such as the lubrication and cooling systems. These details are covered in books on engine design and operation and will not be considered further here.

Engines as used in agricultural tractors may be classified as follows:

- (i) operational cycle * two strokes per revolution
 * four strokes per revolution
- (ii) fuel ignition * spark - gasoline, petrol, natural gas
 * compression - diesel
- (iii) air induction * unlimited- diesel
 * throttled - spark ignition
 * pressurized - super-charged
- (iv) speed control * governed - automatic
 * ungoverned - manual

1.3.2 Power transmission systems and outlets

The transmission systems on the tractor serve to transmit power from the engine to the power outlets, viz:

- (i) traction system (wheels / drawbar / three point linkage)
- (ii) power take off
- (iii) hydraulic (oil) supply

The transmission elements which comprise these systems, may be classified according to their principle of operation:

- (i) mechanical * gears
 * belts / chains
- (ii) hydrostatic * fluid pressure
- (iii) hydro-kinetic * fluid momentum - fluid coupling
 - torque converter

The three transmission systems that transmit power to the three main outlets are discussed below.

(a) Traction transmission

(i) *Conventional tractors*

The components generally referred to as the 'transmission' and / or the 'gear box' transmit the rotation of the engine to the rear wheels as shown in Figure 1.1 and 1.2. In the conventional tractor this is usually a mechanical system with shafts, gears etc. Only this type will be considered in this book; discussion of the hydro-static system may be found in Goodwin (1979) and of the hydro-kinetic system in Vasey (1957-58).

Because the engine rotates at high speed (a few 1000's of rpm) and the tractor wheels must operate at low speed (a few 10's of rpm), the traction transmission has the function of reducing the speed of rotation of the engine to that required for the rear wheels. Further, because not all operations require the tractor to travel at the same speed, the transmission also has the function of enabling the speed reduction from engine to wheels to be varied by the operator. Thus the travel speed may be changed in from 6 to 12 steps, ie, from about 1 km/hr in a 'low' gear with a 'large' reduction ratio (q in Chapter 2) to about 20 km/hr in a 'high' gear with a 'small' reduction ratio. The variable ratio is achieved by 'changing gears' (that are in mesh) so that the drive (motion) passes through gears of different sizes (Figure 1.2). This has the effect of altering the overall ratio of the transmission and causing the wheels to run faster or slower.

The (traction) clutch, (Figure 1.2), which is usually of the friction type, is placed between the engine and the transmission. It enables the driver to temporarily disconnect the engine from the rest of the transmission and to make a gradual connection when power transmission is required and the tractor begins to move. Such transmission clutches usually consist of one or more friction surfaces connected to the engine, which are pressed by springs on either side of a disc connected to the remainder of the transmission. Removal of the pressure on the surfaces (disengaging the clutch with the pedal) allows the engine to continue to turn without turning the transmission and the wheels.

That part of the transmission known as the 'differential' has the function of dividing the drive to the wheels and allowing them to turn at different speeds as the tractor turns a corner. Both wheels still drive because the input torques to them remain equal, but they turn at different speeds, corresponding to the respective radii of the curves on which they are travelling. Many tractors have a device to lock the differential. This forces both of the rear wheels to turn at the same speed and so allows the tractor to be driven out of a situation where the differential, in normal operation, allows one wheel to slip and the other to not rotate at all. With the lock engaged the wheel speeds are now equal but the torques are different; hence it is not possible (or difficult) to turn a corner.

A further common component in the transmission is the 'final drive' which consists of speed reduction gears after the differential. These are placed in this position near the wheels to avoid the low speed / high torque in the previous parts of the transmission.

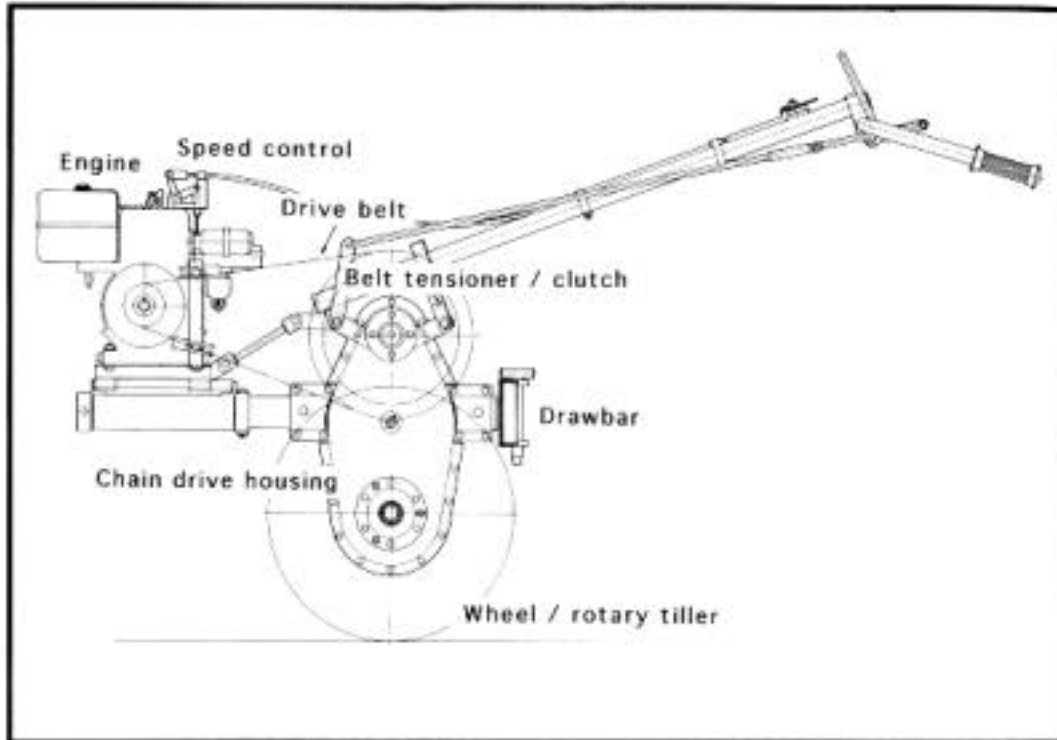

Figure 1.3 (a) Transmission system for walking tractor / power tiller
 (b) Walking tractor being used for ploughing flooded soil
 Reproduced with permission of International Rice Research Institute

(ii) Walking tractor

In the two-wheel or walking tractor (Figure 1.3), the transmission usually consists of a variable speed V belt drive from the engine, which also acts as a clutch as it is tightened or loosened. A small gear-box may then be fitted, which in turn drives the wheels through chains.

Such tractors are not usually fitted with a power take-off but while stationary may be used to drive equipment such as a pump. The belt drive to the wheels is removed and is used to drive the attached equipment directly.

Power losses in the mechanical transmission systems of tractors are usually small, probably less than 10%.

(b) Power take-off transmission

An ('engine speed') power take-off (PTO) which is frequently fitted to conventional tractors consists of a transmission from the engine to shaft which passes to the outside of the tractor, usually at the rear, and may be engaged to drive attached machines (Figure 1.2). The power passes from the engine through a friction clutch which is frequently operated with the same pedal as the transmission clutch. This, and an engaging mechanism, allows the drive to the power take-off to be stopped and started as required, independently from the drive to the wheels. Hence the driven machine may continue to operate and process the crop even though the tractor and machine are not moving forward. This is a very convenient arrangement and a great advantage over older tractors with a single clutch and especially over ground driven machines.

PTO speed is determined by engine speed, (with a fixed ratio 3 or 4:1) irrespective of travel speed (traction transmission ratio). Power losses in the PTO drive are very small, usually less than 5%.

A "ground-speed" PTO may also be fitted (Fig. 1.1). Here the drive to the PTO shaft is connected to the drive to the wheels after the traction transmission and hence the PTO speed changes as the traction transmission ratio is changed. The ground speed PTO rotates slowly (a few revolutions per unit distance traveled) and may be used as a replacement for a ground drive on machines such as seed drills where a fixed relationship between the movement of the tractor and the function of the machine is important.

The two engaging mechanisms for the PTO drive are such that only one of these can be engaged at one time.

(c) Hydraulic (oil) supply

Here oil under pressure from a hydraulic pump, continuously driven by the engine, is available to operate linear actuators (cylinders, rams) usually for the purpose of controlling (raising and lowering) implements, or driving rotating actuators (motors). One such ram, in-built into the tractor, is used to raise the three-point linkage.

Power losses in the hydraulic system may be moderate but are accepted because this outlet is a flexible and very convenient way of controlling machines and operating auxiliaries on the tractor and on attached machines.

The details of the design and operation of the components in the three tractor transmission systems are covered in books on mechanical analysis and machine design. They will not be considered further in this book.



	Surface	Tread form
(a)	Hard surfaces such as roads	Large area, shallow tread with 'high' pressure
(b)	Normal agricultural work, dry soil	Heavy, intermediate depth tread
(c)	Soft, wet agricultural soils	Deep tread
(d)	Lawns, low sinkage is required	Wide, low pressure
(e)	Dry soil, heavy loads as in earthmoving	Tracks, as on a "crawler" tractor
(f)	Saturated, puddled soils	Metal cage, with angled lugs, alone or as extensions to normal tyres

Figure 1.4 Ground drive elements

(a) to (d) reproduced with permission of Goodyear Tyre Company

(e) reproduced with permission of Caterpillar of Australia, Ltd

(f) reproduced with permission of International Rice Research Institute

1.3.3 Wheels

The tractor wheels and associated tyres have the function of supporting the tractor and of converting rotary motion of the engine to linear motion of the tractor as a whole.

The wheels must be chosen to:

- (i) support the weight of the tractor (together with any transferred weight from attached implements) while limiting the sinkage into the soil surface and the resultant rolling resistance.
- (ii) engage with the soil (or surface) and transmit the traction, braking and steering forces (reactions) while limiting relative movement and the resultant slip / skid / side slip.
- (iii) provide ground following ability together with some springing and shock absorption.

The important variables in relation to the tyres include:

- (i) size (diameter and width) which determines their tractive capacity and rolling resistance.
- (ii) strength, expressed in terms of ply rating, which in turn determines the pressure that can be used and hence the weight that the tyre can carry; this in turn also determines the tractive capacity and the rolling resistance.
- (iii) tread pattern which, together with the surface characteristics, determines the engagement and / or contact with the surface.

The losses in power at the wheel / surface interface are often great, particularly on soft surfaces (ie, their efficiency is low), hence the power available at the tractor drawbar may be much less than the power of the engine. Hence the choice of the tyres and the weight on them is crucial in determining the overall performance of the tractor.

Various types of wheels and / or tyres may be used on the tractor, depending mainly on the surface on which it is working. For the following conditions, the tyres or wheels indicated are recommended as shown in Figure 1.4.

1.4 STUDYING TRACTOR PERFORMANCE

1.4.1 Need for study

Before beginning the study, it may be useful to consider those who have an interest in the subject and why they need to study it.

- (i) The designer wishes to predict whether the tractor being designed will achieve the design objectives He / she will do this by means of traditional design procedures for mechanical elements such as the power train, experience gained from measurement of the performance of other tractors and the application of the performance prediction techniques explored in this book.
- (ii) Those who are advisers to the users including extension advisers and sales persons also need to understand tractor performance. Their interest is not in design but in how to choose (in economic as well as physical terms) a tractor from a range available to achieve a required work rate (or match other machines) and how to set it up and operate it in the most efficient manner.
- (iii) Users need to understand the basic aspects of tractor performance so that they can interact with their advisers and work their tractors in an efficient manner.
- (iv) Those who are responsible for providing services such as training, administration, safety and other associated aspects to the above groups also need to understand tractor performance and so provide valid and useful advice.

Given their different roles, their need for training material varies widely. This book will not satisfy all groups but may help to provide an understanding of tractor performance and so assist each group in the preparation of associated material needed to fulfil their roles.

1.4.2 Approaches to the study

(a) Theoretical / ideal

The tractor, which is a machine that is comprised of various simple mechanical elements, can be analysed in terms of their theory. This is presented in Chapter 2 and provides a basic understanding of the operation of the tractor under ideal conditions. However operation of the tractor in the field indicates that this simple analysis is inadequate to determine the limits of its performance as the drawbar load on it is increased, or to predict its performance when operating on soft soils.

(b) Practical / experimental

Historically the study of tractor performance has been in practical, experimental terms. In this approach the tractor is operated under described conditions and its performance measured and reported. A similar performance could be expected from another tractor, of the same model when operated under similar conditions, or from a different make of tractor if appropriate allowances were made for any differences, eg, the weight of the tractor or the engine power.

Examination of the results of performance measurements made for tractors operating on soil shows that the condition of the surface is the most significant factor determining their performance. We cannot compare different tractors tested under such conditions because the effects of the inevitable differences in soil condition on the performance are confounded with, and cannot be separated from, the actual differences between the tractors.

Hence, as in other practical measurement approaches, we begin with the performance measured under ideal conditions. This involves testing the engine on a dynamometer and / or the tractor on a hard surface such as a concrete or bitumen road, ie, on a so called 'test track'. Under these conditions we obtain the maximum or best performance that is possible.

Then, if all tractors are tested on the same or similar surface, the surface effect is (at least partly) eliminated. The conclusion from a comparison of such tests then is that tractors ranked in order of some performance parameter (eg, maximum drawbar power or best fuel economy) as obtained on the test track will be the same rank order as if they were tested in actual operating conditions, ie, on a field soil. This is the same logic as used when we measure the strength of various steels in a testing machine and hence rank the strength of beams made from them.

The reports of formal tractor testing schemes (Nebraska, OECD, etc) and many other research papers are examples of the practical / experimental approach.

Tractor performance as measured in this way is described in Chapter 3 and is satisfactory as far as it goes. However it does not provide a fundamental understanding of the traction process, nor does it provide a basis for the prediction of performance which is the basis of engineering design.

(c) Theoretical / predictive

In this approach we set up a theoretical model (based, like all theoretical work, on some empirical or experimental data) of the way in which the wheels interact with the soil:

- (i) in the vertical direction as it supports the vehicle.
- (ii) in the horizontal direction as it generates the reaction to provide the drawbar pull.

The early work by Bekker (1956) and later work by Reece (1965-66 and 1967) and many others uses the standard properties of the soil (cohesion and angle of internal friction) and an empirical deformation parameter to characterize its strength and deformation properties respectively. These are used to model the generation of shearing stresses within the contact area which are then integrated to give the total reaction of the soil and hence the drawbar pull and power. This is presented in Chapter 4, Sections 4.3 to 4.6.

This approach provides a good understanding of the traction processes and of the effect of the dimensional characteristics of the wheel and the strength properties of the soil. However its application for field use is limited because it involves the complex and time consuming, in-situ measurement of the three soil properties.

(d) Empirical / predictive

This approach is predictive but is based entirely on empirical relationships that have been established between a single soil parameter (together with the dimensions of the wheel) and the tractor performance (Wismer and Luth (1974) . The easily measured parameter (cone index), represented by the force to push a cone into the soil divided by the cross sectional area of the cone, is a complex but ill-defined measure of soil strength and compressibility.

This is a rapid and versatile method of predicting the field performance of tractors. However again it does not provide a basic understanding of the traction process but it does allow a rapid representation of the overall performance as shown in Chapter 5.

1.5 PREVIEW

The theory and explanation which follows in the later Chapters applies to the conventional rear-wheel drive tractor irrespective of what form other features, such as the engine, transmission or steering, may take. With appropriate modifications, as noted in the text, it may also apply to other forms such as the crawler and walking tractors.

In general it does not apply to the four-wheel drive type because with such a system, the drive is divided in an unknown proportion between the front and rear axles in a way that depends on the stiffness of the respective drive trains to the wheels. It also depends on the strength and stiffness of the soil in the soil / wheel contact patch which in turn depends on the respective weights on these wheels.

1.6 REFERENCES

- Bekker, M.G. (1956) *The theory of land locomotion - the mechanics of vehicle mobility*. (University of Michigan Press).
- Goodwin, A.B. (1979) *Fluid Power Systems - theory, worked examples and problems* (Macmillan).
- Liljedahl, J.B., Turnquist, P.J., Smith, D.W. and Hoki, M. (1989): *Tractors and their power units*. 4th Edition (Van Nostrand), Chapter 1.
- Reece, A.R. (1965-66): Principles of soil-vehicle mechanics. *Proceedings of Institution of Mechanical Engineers*, Vol. 180, (2A).
- Reece, A.R. (1967) Tractor design and tractive performance. *Institution of Agricultural Engineers, Agricultural Engineering Symposium*, Paper No 3/4/E/34, Silsoe, England. 9pp.
- Vasey, G.H. (1957-8) Hydraulic torque converters in tractors. *Proceedings of Automobile Division, Institution of Mechanical Engineers*, (4) 103- 117.
- Wismer, R.D. and Luth, H.J. (1974) Off-road traction prediction for wheeled vehicles. *Transactions of American Society of Agricultural Engineers*, 17(1) 8-10, 14.

APPENDICIES

I LIST OF SYMBOLS

II DIMENSIONAL DATA FOR FARMLAND TRACTOR

APPENDIX I
LIST OF SYMBOLS

Symbol	Definition	Defining section
a	distance from drawbar to implement wheels parallel to ground surface	6.4.3
a	constant in normal stress distribution characteristic	4.7
b	distance from drawbar to soil force on implement parallel to ground surface	6.4.3
b	distance from drawbar to trailer wheels	6.4.4
b	width of plate, tyre	4.3.2
c	cohesion of soil	4.4.2
d	depth of cultivation	7.5
d	tyre diameter	5.3.1
d'	constant in implement draught - speed characteristic	7.2.3
h	tyre section height	5.3.1
h	ratio drawbar height / centre of gravity height	6.5
i	wheelslip	2.3.1
i'	wheelslip at maximum tractive power	4.6.2
j	deformation of soil parallel to soil surface	4.4.2
k	shear deformation modulus of soil	4.4.2
k	rate constant	5.3.2
k_c, k	sinkage moduli of soil	4.3.2
l	length of plate, distance traveled by wheel	4.3.2
l	length wheel / track contact with ground	4.3.2
m	distance travelled by wheel	3.3.3
n	number of revolutions of wheel	4.1.5
n	sinkage exponent of soil	4.3.2
p	plate, wheel pressure on soil	4.3.2
q	transmission ratio	2.2.1
r	wheel radius	6.3.1
t	time period	3.2.3
w	width of implement	7.5
x	distance along track	4.4.4
x	distance between the two axles, parallel to the ground surface (wheel base)	6.3.1
x'	distance from rear axle to hitch point (or point of application of implement load) parallel to ground surface	6.4.1
x''	distance between the two axles parallel to the ground surface (tractor raised)	6.3.1
x_f	distance from front axle to centre of gravity of tractor	6.3.1
x_r	distance from rear axle to centre of gravity of tractor	6.3.1
x_h	distance from axle to the handle (walking tractor) parallel to the ground surface	6.4.4
x'_r	horizontal distance from rear axle to weight (tractor raised)	6.3.1
y	distance from rear axle to hitch point (or point of application of implement load), perpendicular to the ground surface	6.4.1
y'	distance from ground contact point to hitch point (or point of application of implement load), perpendicular to the ground surface	6.4.1
y''	height of front axle (tractor raised)	6.3.1
y_g	distance from rear axle to centre of gravity for tractor perpendicular to ground surface	6.3.1
y_t	distance from axle to centre of gravity for trailer perpendicular to ground surface	6.4.4
z	deformation (sinkage) of soil perpendicular to the soil surface	4.3.2
z	distance from ground surface to point of application of soil force perpendicular to the ground surface	6.4.3
z'	slope distance from rear axle to weight (tractor raised)	6.3.1

A	area of wheel, track contact with ground	4.4.3
A	constant	5.2
B	constant	5.2
C	calorific value of fuel	2.4.1
CI	cone index	5.3.1
D	wheel diameter / draught	2.2.1
D	implement draught	7.2.2
F	lift force on implement drawbar perpendicular to the ground surface	6.4.4
FC	fuel consumption rate	3.2.3
H	tractive force / soil reaction parallel to the ground surface	2.2.2
M	mobility number	5.3.1
M	moment on wheel / chassis	6.4.1
N	rotational speed	2.2.1
N	number of revolutions	4.1.5
P	drawbar pull, weight of attached implement	2.2.1
Q	power	2.2.3
Q'	tractive power	4.6.2
R	rolling resistance	2.3.2
R	weight on trailer wheels	6.4.4
S	shear stress	4.4.2
S	soil force	6.4.3
SFC	specific fuel consumption	3.2.1
T	torque	2.2.2
T	force on implement at tractor drawbar, perpendicular to the ground surface	6.4.3
U	force on handles, perpendicular to slope	6.4.4
V	travel speed	2.2.1
V	dynamic weight on wheels	6.4.1
V _s	slip velocity of wheel relative to surface	2.3.3
V'	dynamic weight on implement wheels	6.4.4
W	weight of tractor	6.3.1
W	static weight on wheels	6.3.1
W'	weight of trailed implement, trailer	6.4.1
W' _f	weight on front wheels (tractor raised)	6.3.1
X	slip function	4.4.4
	angle of slope of ground surface	6.4.1
	angle	6.3.1
	tyre deflection	5.3.1
	angle of internal friction	4.4.2
	efficiency	2.4.1
	angle of draught / drawbar pull / implement load to ground surface	6.4.1
	coefficient of rolling resistance	4.3.3
	normal stress	
	tractive coefficient = $\frac{\text{drawbar pull}}{\text{weight on driving wheels}}$	3.3.3
	gross tractive coefficient = $\frac{\text{tractive force}}{\text{weight on wheel}}$	4.4.3

Subscripts

d	drawbar / down
e	engine
f	front wheel
g	centre of gravity
h	handles
n	transmission
o	theoretical, ideal, zero load, overall, zero speed
r	rear wheel
s	static, slip
t	trailer, traction
u	up

APPENDIX II

DIMENSIONAL DATA FOR FARMLAND TRACTOR			
FEATURE	Symbol	Values for	
		Farmland tractor	Local tractor
Weights		kg / kN	kg / kN
Total weight	W	2850 / 27.9	
Weight on rear wheels (on horizontal ground)	W_r	2030 / 19.9	
Weight on front wheels (on horizontal ground)	W_f	820 / 8.0	
Dimensions		metre	metre
Wheel base (front to rear axle)	x	1.88	
Rear axle to C of G (parallel to ground)	x_r	0.54	
Front axle to C of G (parallel to ground)	x_f	1.34	
Rear axle to C of G (perpendicular to ground)	y_g	0.13	
Ground contact to drawbar (parallel to ground)	x'	0.60	
Ground contact to drawbar (perpendicular to ground)	y'	0.45	
Rear axle to drawbar (perpendicular to ground)	y	0.185	
Rear wheel rolling radius (on 14.9 x 28 tyres)	r	0.635	
Overall transmission ratio	q	Ratio	
Gear 1		221.1	
Gear 2		170.0	
Gear 3		139.5	
Gear 4		108.9	
Gear 5		85.6	
Gear 6		67.4	
Gear 7		47.3	
Gear 8		37.1	
Gear 9		22.0	
Gear 10		17.3	
Rev 1		72.3	
Rev 2		56.9	

Index

Air charge	3.3
Air induction, engine	1.4, 3.3
Angle of internal friction, soil	4.14
Braked wheel	4.3
Centre of gravity	6.5
Chassis mechanics	6.1
Cohesion, soil	4.14
Cone index	5.4
Differential	1.6
Draught, implement	7.1, 7.5
Drawbar performance	3.11, 5.12
Drawbar power envelope	3.13
Drawbar power:	2.3, 3.13
Calculated	2.3
Measured	3.11
Predicted	4.24, 4.28, 5.8, 5.16
Drawbar pull	2.3, 3.11, 4.22
Calculated	2.3
Measured	3.11
Predicted	4.22, 5.8, 5.12, 5.16
Drawbar pull envelope	3.10, 4.24, 5.12,
Driven wheel	4.3
Efficiency	
Engine	2.9
Overall	2.9
Tractive	2.8
Transmission	2.8
Engine	1.4
Power	2.3, 3.3, 3.5, 7.11
Speed	3.3, 3.5
Torque	2.3, 3.3
Efficiency	2.9
Engine operational cycle	1.4
Engine performance	
Measured	3.3
Predicted	5.1
Engine performance modeling	5.1
Engine power envelope	3.10, 3.12
Engine speed control	1.4
Farmland tractor details	Appendix II
Fuel consumption	
Engine	3.7
Drawbar	3.13
Full fuel range	3.4
Fully mounted hitch	6.3, 6.23
Functional performance	1.2
Gear box	1.6
Governed range	3.4
Governor	3.3
Gross tractive coefficient	4.16
Ground drive elements	1.2

Hitch systems	6.3
Hitch systems – comparison	6.26
Trailed	6.1, 6.26
Semi-mounted	6.1, 6.26
Fully-mounted	6.1, 6.26
Ideal performance	2.4
Implement	
Draught	7.1, 7.5
Unit/ specific draught	7.2
Hitching	6.1
Power	7.3
Characteristic	7.3
Instability - longitudinal	6.8, 6.36
Matching tractor and implement	7.1, 7.10, 7.12
Mobility number	5.4
Normal stress	4.14
Optimum tractor-implement performance	7.5, 7.10
Overall efficiency	2.9
Performance	
Empirical / predictive	1.12, 4.6
Practical / experimental	1.11, 3.1
Theoretical / ideal	1.11, 2.1
Theoretical / predictive	1.11, 4.6
Performance envelope	2.5, 3.11, 3.13, 7.14, 5.12,5.16
Plate sinkage test	4.8
Power distribution	5.14
Power loss	2.7, 5.14
Power outlets	1.4
Power take-off	1.8, 6.31
Power train	1.3
Rigid wheel	4.12
Rolling radius	4.1
Rolling resistance	4.1, 6.15
Theoretical	4.8
Measurement	4.14
Empirical	5.6
Rolling resistance coefficient	4.12, 5.6
Self propelled wheel	4.3, 4.6
Semi-mounted hitch	6.3, 6.21
Soft wheel	4.12
Soil	
Cohesion	4.14
Friction, angle of internal	4.14
Soil shear	4.14
Deformation modulus	4.14
Soil sinkage	
Exponent	4.6
Modulus	4.6
Soil, cone index	5.4
Specific fuel consumption	
Engine	3.7
Drawbar	3.13, 5.16

Three point linkage	6.3, 6.23
Torque 'back up'	3.5
Towed wheel	4.3
Towing force	4.3
Tractive coefficient	2.10, 3.14, 4.16, 5.6
Tractive efficiency	2.8, 3.14, 7.11
Measured	2.8
Predicted	5.10, 5.16
Tractive force	2.3, 4.6
Ideal	2.3
Predicted	4.14
Tractive performance	4.6,
Theoretical	4.14
Modeling	5.2
Tractor – implement matching	7.1
Tractor operation	7.14
Tractor performance, justification	1.10
Tractor testing	3.1
Trailed hitch	6.1, 6.33
Trailer, PTO driven	6.31
Transmission	1.6
Ratio	2.1
Transmission efficiency	2.8
Travel speed	2.1, 2.7, 3.11, 4.1
Two-wheel (walking) tractor	1.8, 6.28
Tyres	1.10
Walking (two wheel) tractor	1.8, 6.28
Weight transfer	6.8, 6.11, 6.15, 6.26
Trailed	6.21
Semi-mounted	6.21
Fully-mounted	6.23
Wheel, operational state	4.3
Braked	4.3
Driven	4.3
Self propelled	4.3
Towed	4.3
Wheel, performance	
Power	2.7
Speed	2.1
Torque	2.3
Wheel, type	2.1
Tractor	1.10
Soft	4.12
Rigid	4.12
Wheelslip	2.7, 3.14, 4.1, 4.4, 4.20
Optimum	4.26
Function	4.22
Measurement	4.4